

STAINLESS STEEL 90° LIQUIDTIGHT CONNECTORS

APPLICATION

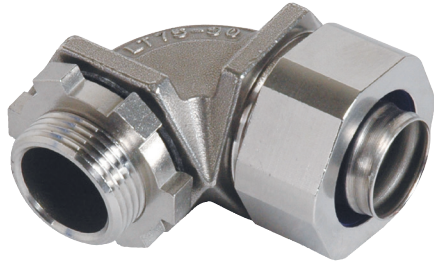

- Designed for use with liquidtight conduit
- Provide a means of connecting to boxes in wet or dry locations
- Offered in three configurations: Straight, 45°, 90°
- Supplied complete with a Type 316 SS gland nut, polyethylene sealing ring, Type 316 SS ferrule, neoprene sealing gasket, and Type 316 SS locknut
- Type 316 SS inside ferrule provides extra corrosion resistance on inside of fitting (Other inside ferrules made of materials such as carbon steel may corrode easily, effecting the entire fitting.)
- Manufactured in stainless steel to help prevent corrosion
- Can be installed using ordinary hand tools and require little maintenance or repair
- Provided in a bright, polished finish that does not require touch up or painting

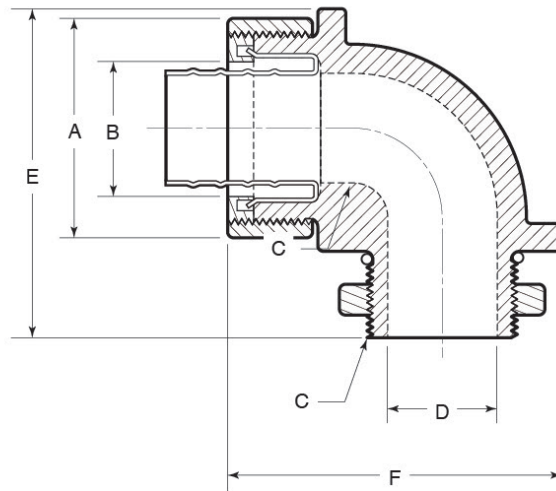
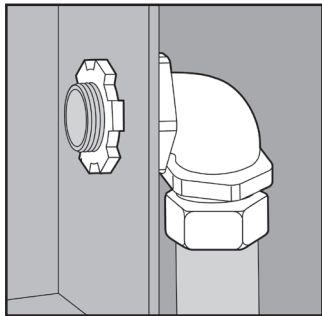

PRODUCT DETAILS

Material:

- Body: CF8M (316 SS)
- Locknut: 316 SS
- Sealing Gasket: Neoprene
- Inside Ferrule: 316 SS
- Sealing Ring: Polypropylene
- Gland Nut: 316 SS

Standards:

ASTM A351, ASTM A240

Country of Origin:

Manufactured in USA

Part Number	Conduit Size	Weight/ 100 (lbs.)	Dimension (in.)					
			A	B	C	D	E	F
LT50-90	½ in.	45	1.58	0.86	½-14 NPT	0.62	1.80	2.40
LT75-90	¾ in.	61	1.60	1.06	¾-14 NPT	0.78	2.08	2.65
LT100-90	1 in.	86	1.90	1.33	1-11½ NPT	1.00	2.35	3.00

